

Soil Properties

What is soil?

A soil is a porous medium consisting of minerals, organic matter (OM), water and gases.

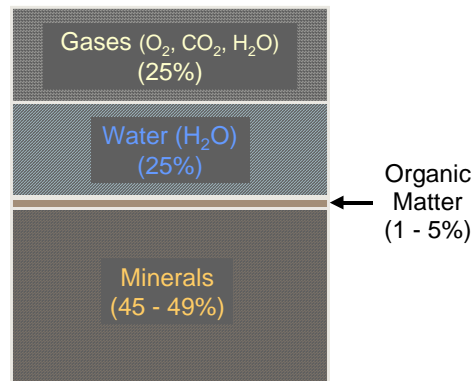

The traditional definition of soil is:

Soil is a dynamic natural body having properties derived from the combined effects of **climate** and **biotic activities**, as modified by **topography**, acting on **parent materials** over **time**.

Climate, biotic activity, topography, parent material, and time are considered the **five soil-forming factors**.

- (1) **Parent materials** are the minerals and organic materials present during the formation of a soil. These materials have not yet been affected by the remaining soil forming factors. Examples of parent materials include materials from volcanoes, sediment transported by wind, water, or glaciers, or minerals left behind by drying lakes.
- (2) **Climate** is the average temperature and moisture of a region. Climate affects soils through the frequency of freeze-thaw (temperature) and wet-dry (moisture) cycles
- (3) **Biota** consists of the plants and animals that help to create a soil. As plants and animals die, they decompose. The resulting organic matter is incorporated with the weathered parent material. Living animals such as moles, earthworms, bacteria, fungi, and nematodes are all busily moving through or digesting food and organic matter found in the soil. All of these actions mix and enrich soil.
- (4) **Topography** is the hilliness, flatness, or the slope of the land. Topography affects soil through the combined influence of moisture and erosion, which alter the type of soil found in a particular location. In many areas, moist/poorly drained soils are located in low areas and depressions. In contrast, soils in sloping areas can be drier and well-drained. These soils tend to be moderately- or well-developed. Erosion, which is enhanced by topography, can remove all or part of the topsoil and subsoil, leaving weakly-developed soil behind.
- (5) **Time** is important, because it takes about 500 years to form 1 inch of soil from parent material. Only the top few inches of a soil are productive in the sense of being able to sustain plant growth. This is why **soil conservation** is so important. It is also the reason that the **Dust Bowl** of the 1930s was so devastating....even after the drought ended (<http://www.usd.edu/anth/epa/dust.html>).

The soil profile

The **organic (O) horizon** consists of detritus, leaf litter and other organic material on the surface of the soil. This layer is dark because of decomposition. This horizon does not exist in all soils.

The **A horizon, or topsoil**, is usually darker than lower soil layers, and is loose and crumbly with varying amounts of organic matter. This horizon is usually the most productive layer of the soil.

The **E horizon**, not shown here, is the zone of maximum eluviation (maximum transport of minerals downward to the B horizon). It is light in color with decreased pH. There are few roots in this zone.

The **B horizon, or subsoil**, is usually lighter in color, dense, and low in organic matter content. Most of the materials leached from the A horizon stop in this zone. Because of this leaching, the B horizon has a higher clay content than the A horizon.

The **C horizon** is a transition area between the soil and the parent material. This is the area in which parent material has only just begun to develop into soil.

At some point, the C horizon will lead to the **final horizon: bedrock or parent material**.

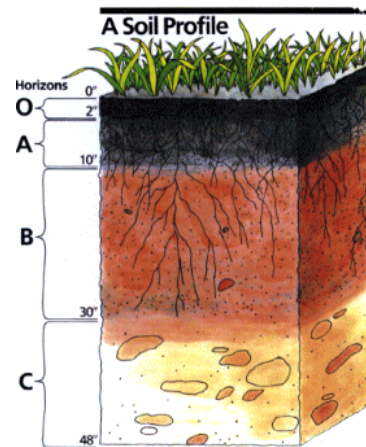
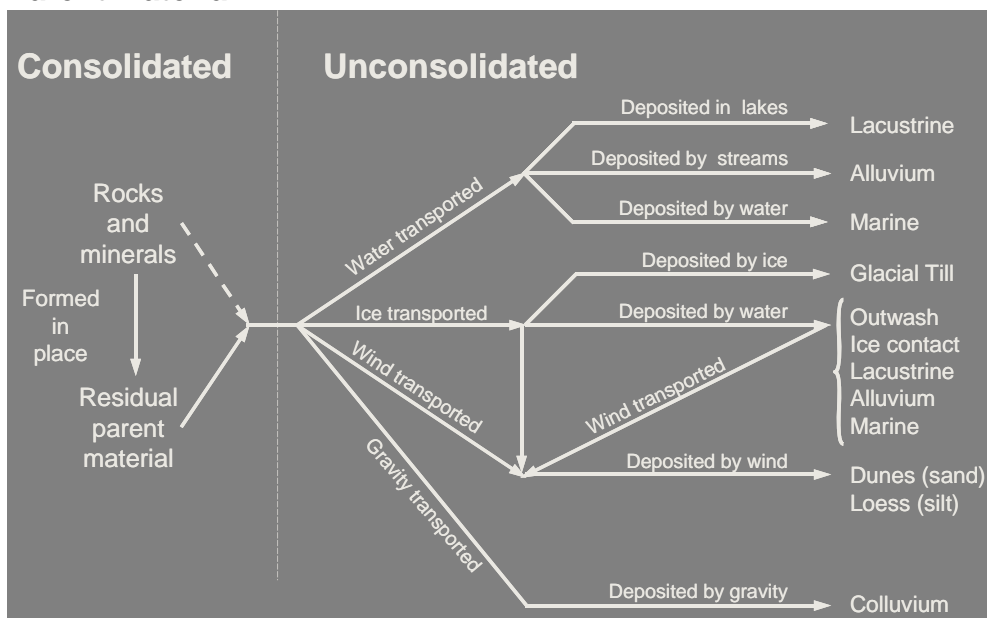

Image from:

<http://www.mo15.nrcs.usda.gov/features/gallery/gallery.html>

Collectively, these horizons are known as a soil profile. The thickness of the soil horizons and of the profile itself varies with location and disturbance (e.g., agriculture, construction, severe erosion). As water moves through the topsoil, many soluble minerals and nutrients dissolve. These dissolved materials leach downward into lower horizons, which is why the B horizon has higher clay, iron and aluminum contents than the A horizon. Not all horizons will be found in all locations. For example, a very young soil will consist only of the A and C horizons.

Parent Material



This figure is adapted from Brady *The Nature and Property of Soils, Eleventh Edition.*

Parent material is that material from which soil is derived. It can be consolidated (formed in one place, such as rocks and minerals) or unconsolidated. Unconsolidated parent material has been created in one place and transported by water, ice, wind, and/or gravity to another location. This parent material is then deposited and the process of creating soil begins. One of the common types of unconsolidated parent materials found in Western Montana is **talus**, consisting of rock fragments that are transported by **gravity** and accumulate at the foot of cliffs or steep slopes.

Climate

Climate can have a dramatic effect on the weathering of parent material as the figure from Strakhov (1967) shows.

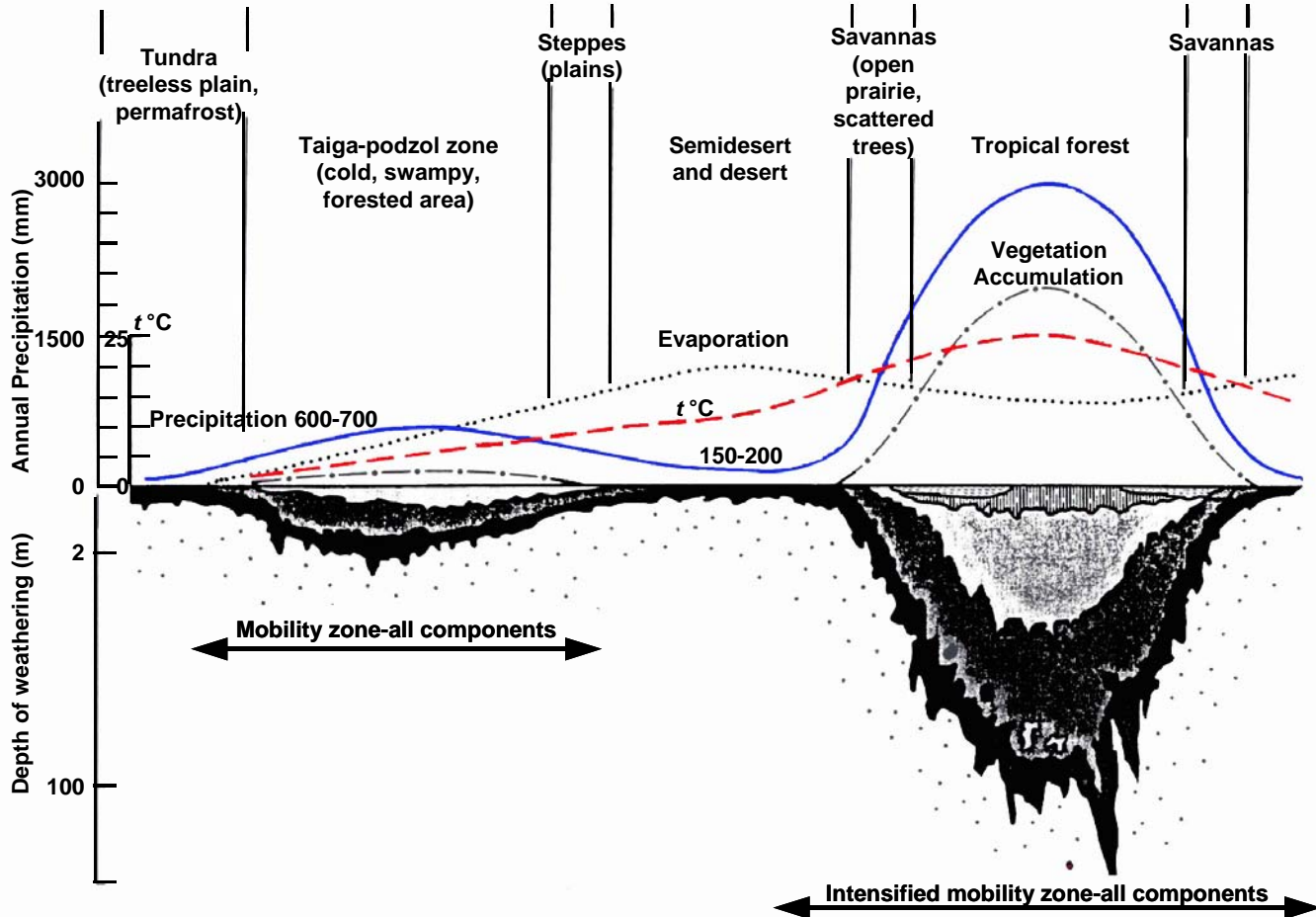

(Strakhov, 1967)

From Aber and Melillo, *Terrestrial Ecosystems*, Figure 9.4

The warm, wet climates of tropical forests result in the most weathered soils. Less weathering occurs in cold, wet temperatures of the boreal zone (taiga). The areas with the least weathered soils are the semi-deserts and deserts, indicating the importance of moisture to the weathering process.

Physical Properties of Soil

Soil Texture

Soil comes in a variety of textures, but result from two principal mineral types. **Primary minerals**, such as those found in sand and silt, are those soil materials that are very similar to the parent material from which they formed. They are often round or irregular in shape. **Secondary minerals**, on the other hand, result from the weathering of the primary minerals, leading to the formation of plate-like micelles (clay). Clays have a large surface area, which is important for soil chemistry. The **texture of a soil is based on the %sand, %silt, and %clay** found in that soil. The identification of sand, silt and clay are made based on size.

In the U.S., we use the following definition:

- Sand 0.02 – 2.00 mm in diameter
- Silt 0.002 to 0.02 mm in diameter
- Clay <0.002 mm in diameter.

The texture of a soil can be determined from its sand, silt, and clay content using a textural triangle. The triangle on the right is the one created by the USDA NRCS (Natural Resources Conservation Service) and is primarily used in the United States. There are various different textural triangles used throughout the world, but most of them are similar.

Percent clay in this triangle is read on the left-hand side of the triangle, and the lines are horizontal. The percent silt is read on the right-hand side of the triangle, and the lines are read from upper-right to lower-left. The percent sand is on the bottom of the triangle, and the lines travel from lower-right to upper-left.

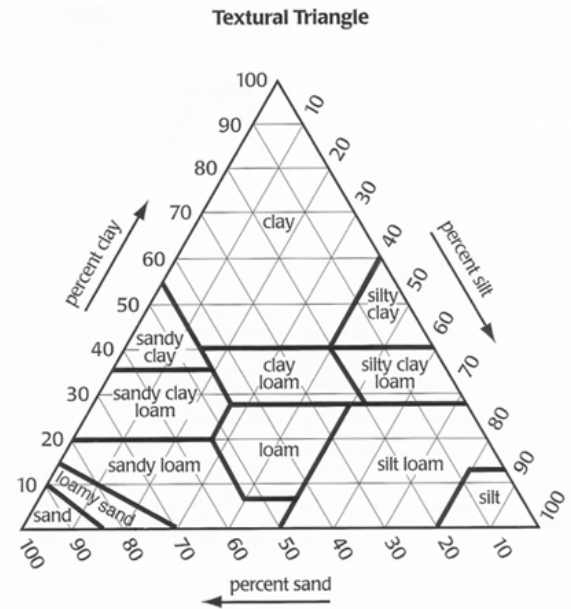

For example, if a soil contains 20% clay, 40% sand, and 40% silt (total = 100%!!), then it is a **loam**.

What is the texture of a soil containing 35% clay, 40% silt, and 25% sand?

Soil Structure

Soil structure is the formation of secondary structures called **aggregates** from sand, silt, and clay. These aggregates are held together by (a) organic secretions by plants, (b) microbial gums, and (c) soil wetting/drying actions.



from <http://www.waite.adelaide.edu.au/school/Soil/work.html>

STRUCTURE IS NOT TEXTURE! Texture is the amount of sand, silt and clay in a soil. Structure is how that sand, silt, and clay is aggregated together. Good soil structure improves soil **air** and **water**

relations for both roots and microbes. Remember, respiration requires oxygen, so both roots and microbes require oxygen to survive. But, plants also require water, which they get from the soil, for photosynthesis. So, they need a good **mix** of air and water in the soil for survival. Structure creates pores in the soil. Think of a jar full of large marbles.



There are a lot of spaces in that jar, right? Now, replace the marbles with aggregates of the same size. There are still a lot of big spaces in the jar. Those spaces are called **macropores**. Macropores are, as the name suggests, large pores in the soil. Water will drain quickly from these pores because of gravity. Therefore, **macropores are important for air relations in the soil**. Aggregates themselves are composed of lots of sand, silt, clay and organic matter pieces stuck together (each large marble is really made up of a lot of small marbles that have been glued together). Inside the aggregate are lots of small pores called **micropores**. These pores prevent water from draining out of the soil because the matric potential of the soil particles surrounding the micropores is greater than the gravitational potential. Therefore, **micropores are vital for soil water relations**. If a soil contains only large sand particles, there are no **micropores**, only **macropores**. Water

drains quickly from the soil, leaving little for plant growth. If a soil contains only small clay particles, there are only **micropores**. So, water remains in the soil, and the roots and microbes cannot get air. This is the reason that aggregation is so important. In both cases, an effective method of improving soil structure is adding organic matter to the soil, and thus its air-water relations. You can do NOTHING to improve texture, only structure. For more information on matric and gravitational potential or air-water relations within different soils, see your notes on water relations.

Chemical Properties of Soil

The chemical properties of a soil are just as important as the physical properties. In general, nutrient cycling can be summarized in the following figure...

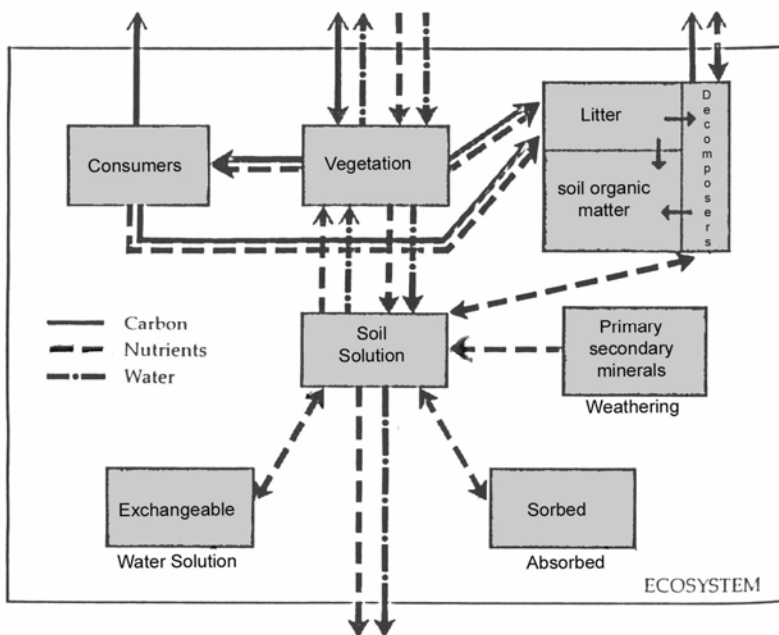

From Aber and Melillo, Terrestrial Ecosystems, Figure 9.1

Nutrients come from a variety of sources: decomposed organic matter, soil mineral weathering, fertilization, etc. There are two types of nutrients needed by plants: macronutrients and micronutrients. **Macronutrients**, as the name suggests, are needed in large quantities.

The Macronutrients

Element	Biochemical Function	Form Assimilated	Source(s)
Carbon (C) Hydrogen (H) Oxygen (O)	Form the basic building blocks of all biologically-active compounds	CO ₂ , H ₂ O, O ₂	Atmosphere
Nitrogen (N)	Nucleic acids, amino acids, proteins, chlorophyll	NH ₄ ⁺ , NO ₃ ⁻	Fertilizer Air Deposition
Phosphorus (P)	Nucleic acids, nucleotides, sugar phosphates, energy transport (ATP)	H ₂ PO ₄ ⁻	Fertilizer Bone meal Superphosphate
Potassium (K)	Enzyme cofactor, osmotic regulation (<i>stomatal control!</i>), cell ion balance	K ⁺	Soil minerals Organic matter Fertilizer
Calcium (Ca)	Cell wall formation, pectin synthesis, metabolism/formation of nucleus and mitochondria, enzyme activator	Ca ²⁺	Dolomitic limestone Gypsum (limestone) Superphosphate
Sulfur (S)	Amino acids, proteins, sulfolipids	SO ₄ ²⁻	Rainwater Impurities in low-grade fertilizers
Magnesium (Mg)	Chlorophyll, enzyme cofactor	Mg ²⁺	Soil minerals Organic material Fertilizer Dolomitic limestone

Micronutrients, on the other hand are needed only in very small quantities. In fact, too much of a micronutrient is almost as bad as too little.

The Micronutrients

Element	Biochemical Function	Source(s)
Iron (Fe)	Formation of chlorophyll	Soil minerals Iron sulfate Iron chelate
Boron (B)	Helps in use of nutrients; regulates other nutrients Aids production of sugar and carbohydrates Essential for seed and fruit development	Organic matter
Manganese (Mn)	Enzymes for breakdown of carbohydrates Nitrogen metabolism	Soil minerals
Copper (Cu)	Reproductive growth Root metabolism Helps in utilization of proteins	??
Zinc (Zn)	Transformation of carbohydrates Regulates consumption of sugars Part of enzyme system that regulates plant growth	Soil minerals Zinc oxide Zinc sulfate Zinc chelate
Molybdenum (Mo)	Helps in use of nitrogen	Soil minerals
Chloride (Cl)	Aids plant metabolism	Soil minerals

A mnemonic to help you remember the necessary plant nutrients is:

C HOPKNS CaFe, Mg B Mn CuZn MoCl

(Pronounced as: "**See Hopkins Cafe, Managed by my cousin Mozel.**")

(Don't ask me how they got Mozel from MoCl; I don't know! ☺)

I learned it as "See Hopkins Cafe, Managed by mine [*sic*] cousins Mo and Clo."

Use whichever one makes more sense to you.)

Some scientists believe that Sodium (Na), Silicon (Si), and Nickel (Ni) should be added to the list, but they aren't currently considered to be **essential** nutrients.

Most **nutrients** are **supplied** by processes occurring in soils such as:

- ion exchange reactions
- mineral weathering of soils, and
- organic matter decomposition.

Nitrogen often limits the growth of many boreal and temperate forests.
Phosphorus often limits the growth of humid tropical forests.

How do nutrients get into plants?

Most of the nutrients required by plants are cations (i.e., they have positive charges). Therefore, nutrients get into plants via a process known as cation uptake.

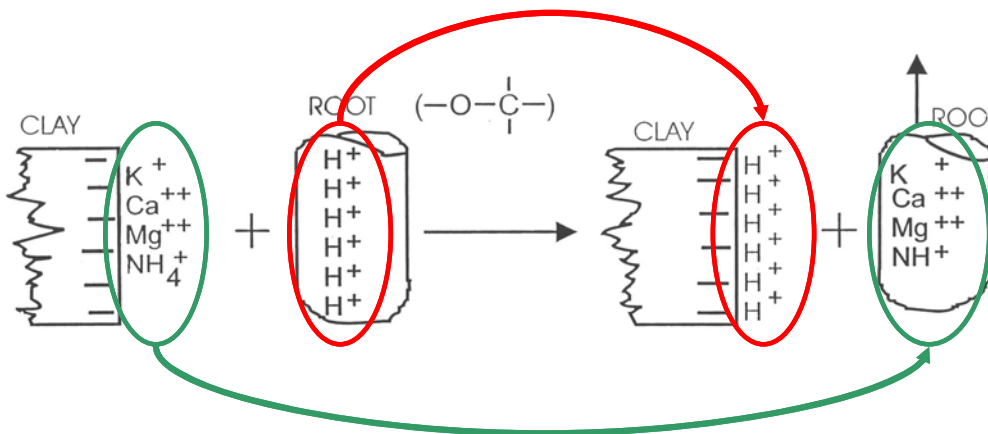

In a **very** simplified form, the roots produce **excess H⁺ ions**. The root/soil system wants to be in **chemical equilibrium**, so these **hydrogen ions** are moved from the root into the soil solution. Now, there are excess **hydrogen ions** in the soil solution. So, the **nutrients (in this case, K⁺, Ca²⁺, Mg²⁺, and NH₄⁺)** move into the soil solution, and change places with the **hydrogen ions**. This is known as cation exchange. Then, since there are now more nutrients in the soil solution than in the plant root, the **nutrients** travel via a chemical gradient, into the root. From there, **they** are transferred via the xylem to the appropriate areas of the plant. This is a **charge-for-charge** exchange, not a molecule-for-molecule exchange! There are **6 + charges** on the clay colloid, so there must be **6 hydrogen ions** to replace them, since each **hydrogen ion** has a **charge of +1**. The number of cations (or positive charges) that can be held on a soil surface and then used in exchange (such as K⁺ for H⁺ in the above picture) is known as the **cation exchange capacity (CEC)** of that soil.

How do the nutrients get into the soil?

Mineralization is the conversion of nutrients from their organic to inorganic forms during decomposition. So, in a process very similar to the above, **mineralization** occurs, and nutrients move from the decaying plant material onto the soil colloids.

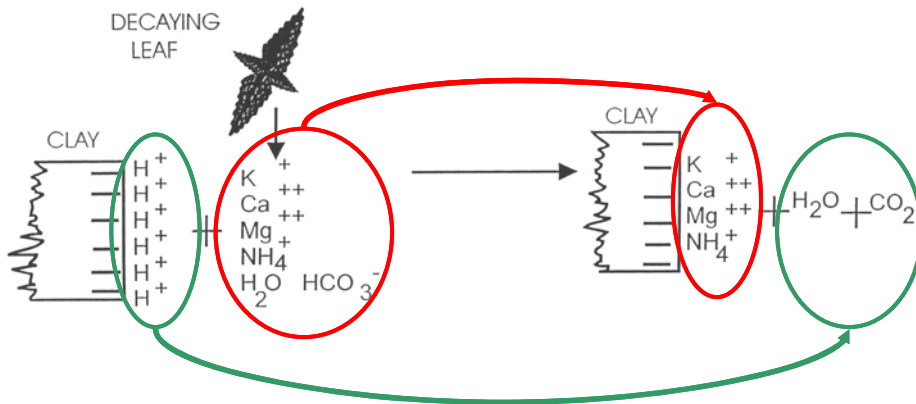

Chemically active soil components

There are only two parts of the soil which are considered to be chemically active: **clay** and **organic matter**. This is because, compared to everything else in the soil, they:

- have a large surface area per unit volume (lots of places for reactions to take place).
- they are electrically charged (have a large negative charge, and can attract many cations)
- high adsorptive capacity (can hold large amounts of cations because of their large (-) charge)
- they are cohesive

Soil Organic Matter

Soil organic matter is a small fraction (1-5%) of most forest soils. It can originate above- (leaves, stems, animals, etc.) or belowground (roots, microbes, animals, etc.) Organic matter has a large impact on the **physical**, **chemical**, and **biological** properties of soil. **Physically**, soil organic matter contributes to aggregate formation, influencing water and oxygen availability. **Chemically**, they store plant nutrients, supplying most of the nitrogen in forest ecosystems. **And, biologically**, they are used for the growth and maintenance of microbial populations in the soil, which are vital to nutrient cycling as they are the primary decomposers of organic matter.

Factors that **control the rate of residue decomposition** include:

Nitrogen content – as the nitrogen content of the soil increases, so does the rate of decomposition. Microbes also require nitrogen, so more nitrogen generally means more microbes. And, more microbes means more decomposition.

Oxygen content – Microbes also require oxygen. As the oxygen content of the soil increases, microbes become more active and more numerous, increasing decomposition

C:N ratio – the C:N ratio is how much carbon there is in the residue as compared to how much nitrogen. Residues with lots of carbon and little nitrogen (a high C:N) are very hard for microbes to digest, because the microbes have to get the nitrogen they require from somewhere else. Residues with a low C:N have more nitrogen for microbes, so they are easier to digest. Generally, microbes will attack residues with low C:N ratios first, and then consecutively more difficult residues.

Presence of salts – Salts inhibit decomposition rates because they impact microbial populations and viability. Thus, high salt content means slow residue decomposition.

Type of residue – The type of residue has a lot to do with its decomposition. Residues that are easy to decompose (sugars, cellulose) will be digested first. These residues have a low C:N ratio and are chemically simple. As residues become more complex (lignin), it is more and more difficult for microbes to break them down. Complex residues tend to have a very high C:N ratio and are chemically complex. Eventually, there is a compound left in the soil called humus. It is VERY complex and has little nitrogen. Humus can exist for thousands of years in a soil.

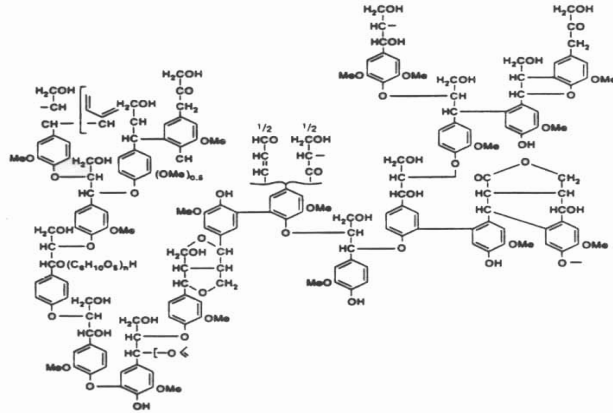
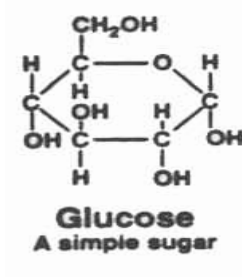

A hypothetical lignin molecule.



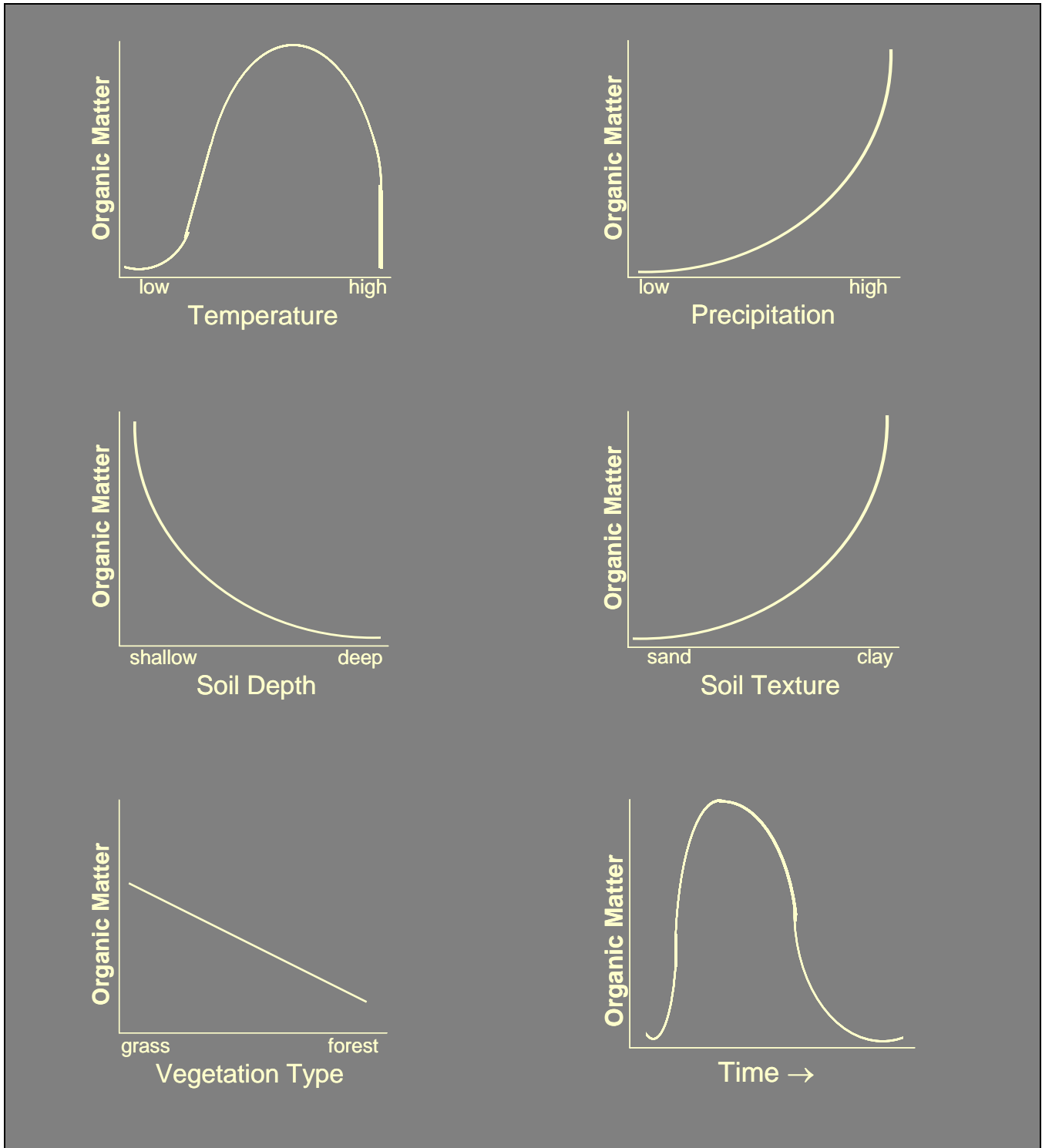





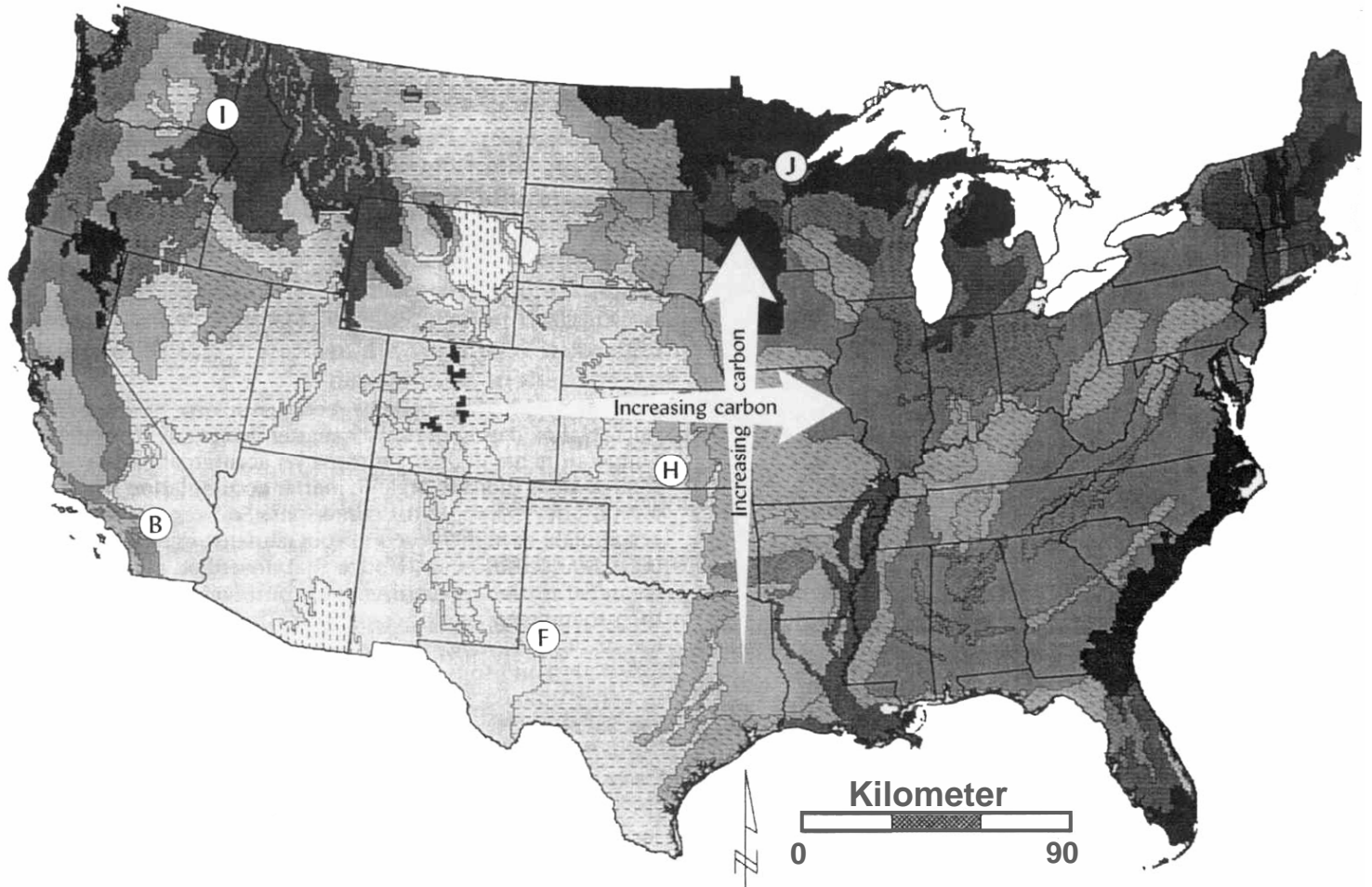

The organic matter content of a soil is dependent on a number of factors. The following graphs summarize these effects. Can you figure out, based on our studies so far, why these graphs look as they do?



The organic matter content of soils in the U.S. (kg m^{-2})

Why is the highest concentration of organic matter found in the northeastern U.S.? (Hint: There are 2 primary reasons).



 0.8	 1.5 to 1.6
 0.9	 1.7 to 1.8
 1.0	 1.9 to 2.0
 1.1 to 1.2	 2.1 to 2.2
 1.3 to 1.4	 2.3 to 7.0